

THIS DRAWING IS UNPUBLISHED. RELEASED FOR PUBLICATION ,19 .

© COPYRIGHT 19 BY AMP INCORPORATED. ALL RIGHTS RESERVED.

LOC	DIST	REVISIONS			
P	LTR	DESCRIPTION	DATE	DWN	APVD
G	14	L	REVISED & REDRAWN PER 0L20-0086-96	29OCT96	DKS DMS

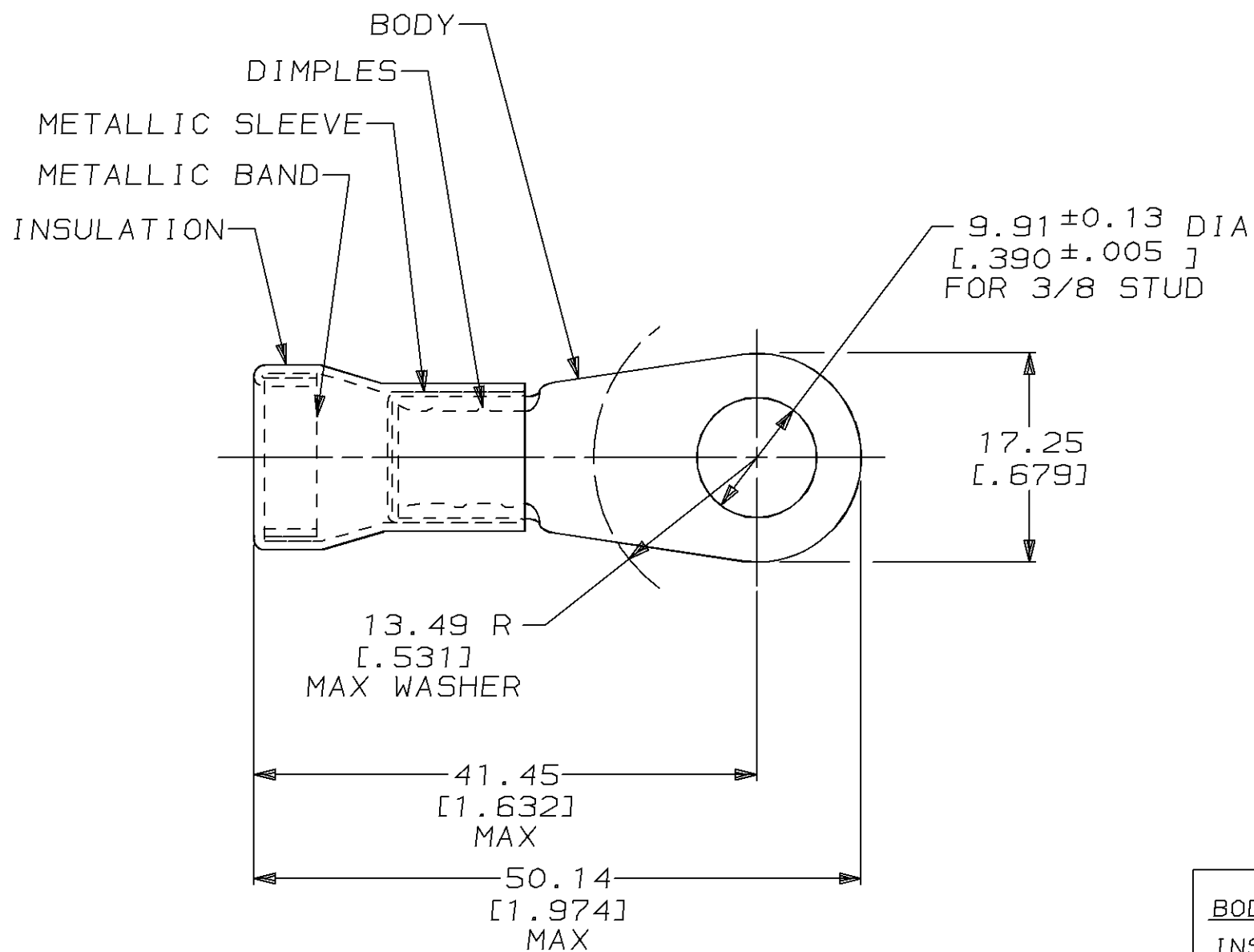

- ① TIN PL 0.00254 [0.000100] MIN THK PER MIL-T-10727
- ② SILVER PL 0.00508 [0.000200] MIN EXT THK PER QQ-S-365
- ③ GOLD PL 0.00127 [0.000050] MIN EXT THK PER MIL-G-45204 OVER NICKEL PL 0.00762 [0.000030] MIN EXT THK PER QQ-N-290
- ④ TAPE MOUNTED
- 5 WIRE INSULATION: 11.07 [0.436] MAX DIA
- 6 MATERIAL THK: 1.22 ± 0.08 [0.048 ± 0.003]

BODY: COPPER PER ASTM B-152 ANNEALED	④ 2-322011-5 ①
INSULATION: PVC COLOR: YELLOW	
METALLIC SLEEVE: COPPER PER ASTM B-152 ANNEALED	2-322011-2 ③
METALLIC BAND: STEEL PER ASTM A-109	2-322011-1 ②
TIN PL 0.00254 [0.000100] MIN THK PER MIL-T-10727	322011 ①
MATERIAL & FINISH	AMP PART NUMBER

AMP INCORPORATED CUSTOMER SERVICE SYSTEMS

FOR ADDITIONAL PRODUCT INFORMATION OR COPIES OF DRAWINGS AND TECHNICAL DOCUMENTS	PRODUCT INFORMATION CENTER 1-800-522-6752
FOR APPLICATION TOOLING INFORMATION	TOOLING ASSISTANCE CENTER 1-800-722-1111
FOR ORDER ENTRY	1-800-526-5142

RECOMMENDED OPERATING TEMPERATURE: 105°C MAX
VOLTAGE RATING: NOT APPLICABLE
WIRE CROSS SECTIONAL AREA RANGE: 16.8-26.7mm ² [33,100-52,600] CIR MILS SOLID OR STRANDED

THIS DRAWING IS A CONTROLLED DOCUMENT.

DIMENSIONS: mm [INCHES]	TOLERANCES UNLESS OTHERWISE SPECIFIED:
	0 PLC ±-
	1 PLC ±-
	2 PLC ±0.20 [0.008]
	3 PLC ±-
	4 PLC ±-
	ANGLES ±-
MATERIAL SEE TABLE	FINISH SEE TABLE

DWN DK SCHRUM 28OCT96
CHK DM SWARTZ 29OCT96
APVD JL MECKLEY 29OCT96
PRODUCT SPEC -
APPLICATION SPEC -
WEIGHT -
CUSTOMER DRAWING

AMP Incorporated Harrisburg, PA 17105-3608		
NAME TERMINAL ASSEMBLY, RING TONGUE, AMPLI-BOND™, WIRE SIZE: 4 AWG		
SIZE A3	CAGE CODE 00779	DRAWING NO C-322011
SCALE 2:1	SHEET 1 OF 1	REV L